

Art. 8694 Hot-dip galvanised CorSTRUT cantilever arm with rail prop

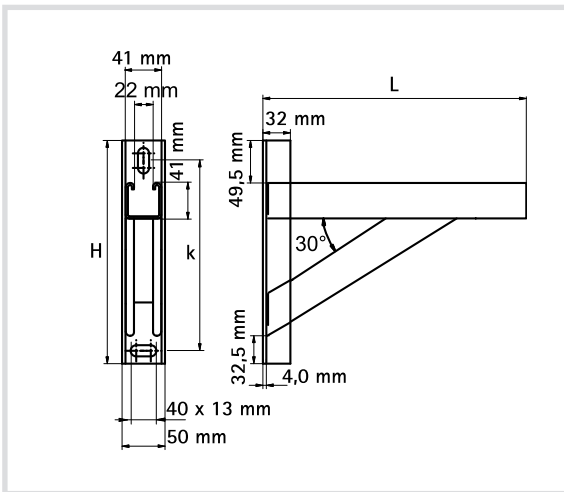

Caratteristiche tecniche

- Made of 1.0332 steel
- Hot galvanised
- With CO₂ welded rail prop



Code	L [mm]	H [mm]	Fixing rail	k [mm]
8694060	600	350	41 x 41	311,5

