

Art. 8693 Rail prop for CorSTRUT

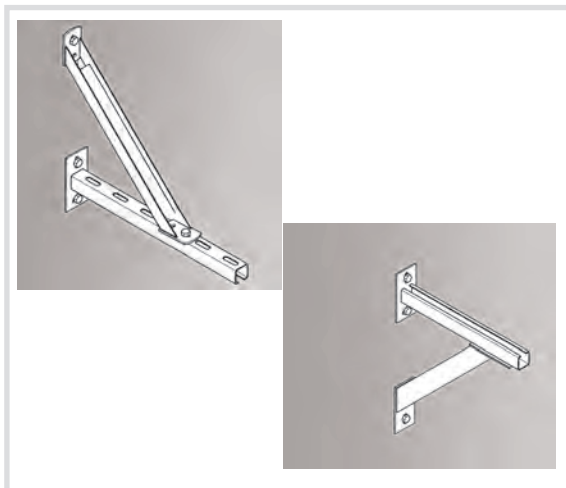

Technical specifications and advantages

- Made with S235JR steel
- Galvanised
- CO₂ welding
- Made using Strut fixing rail
- To increase the load by fixing above or below the cantilever arm
- 45° inclination
- Very elongated slot to ensure the correct coupling is used with the holes of the cantilever arm

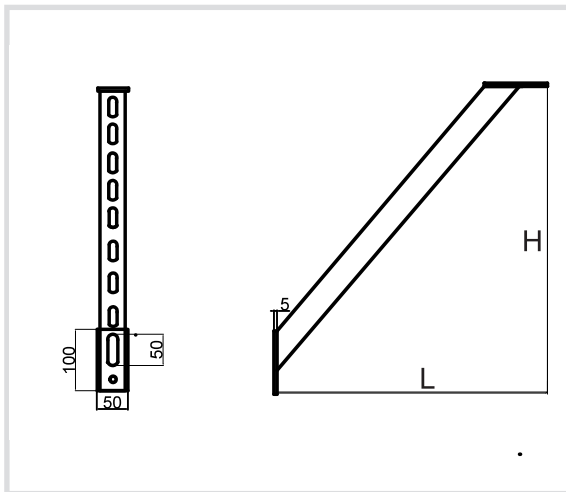

Code	L [mm]	H [mm]	Slotted hole [mm]
8693340	340	340	50x13
8693510	540	540	50x13