

Art. 975 CORH PFM2 - Fixed point on cantilever arm

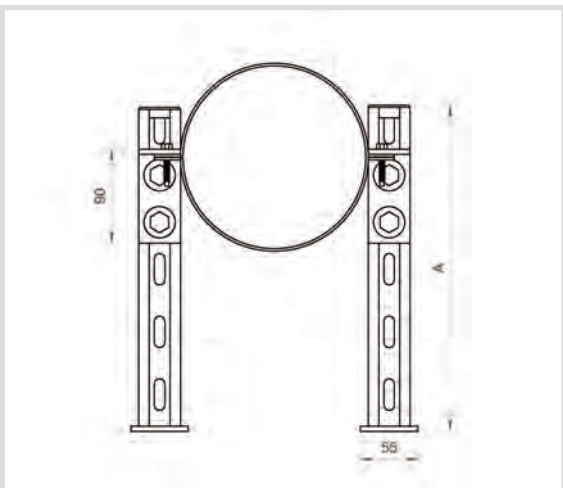
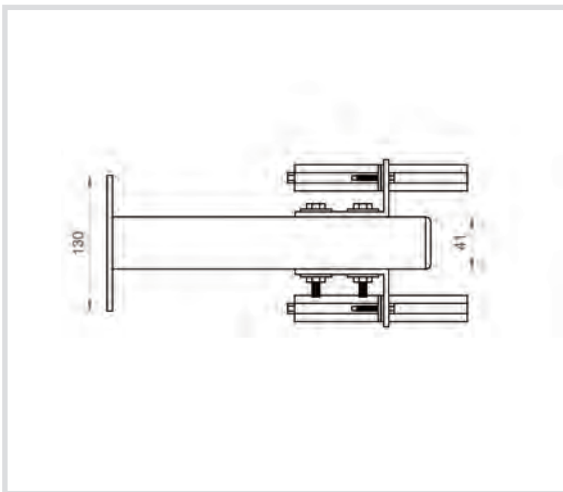

### Technical specifications and advantages

- Ideal solution for pipes subject to significant contractions and/or expansions
- Suitable for all types of fixed point, both with horizontal and vertical pipe
- Possibility of adjusting the distance
- In galvanised steel
- Components for standard fixed point: 2 cantilever arms, 4 special 90° angle brackets, 2 heavy clamps
- On downpipes it may be sufficient to use 1 clamp, instead of 2, as a guide
- It is possible to insert bracing to increase the axial resistance
- The clamps are not included in the package

Code	A (mm)	Payload (N)
<b>975200</b>	200	2300
<b>975300</b>	300	2300
<b>975450</b>	450	2300
<b>975600</b>	600	2300

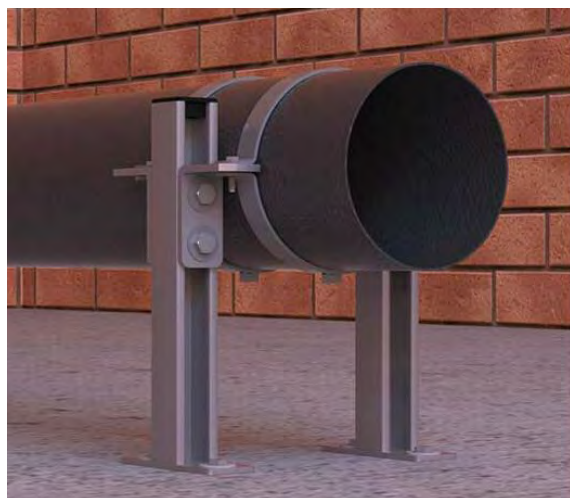

### SPECIFICATION ITEM

Supply and installation of brackets with fixed point for pipes subject to thermal expansion on cantilever arm with distance adjustment for both horizontal and vertical pipes, in S235JR steel, with all the relative fastening components.