

CorRail applications

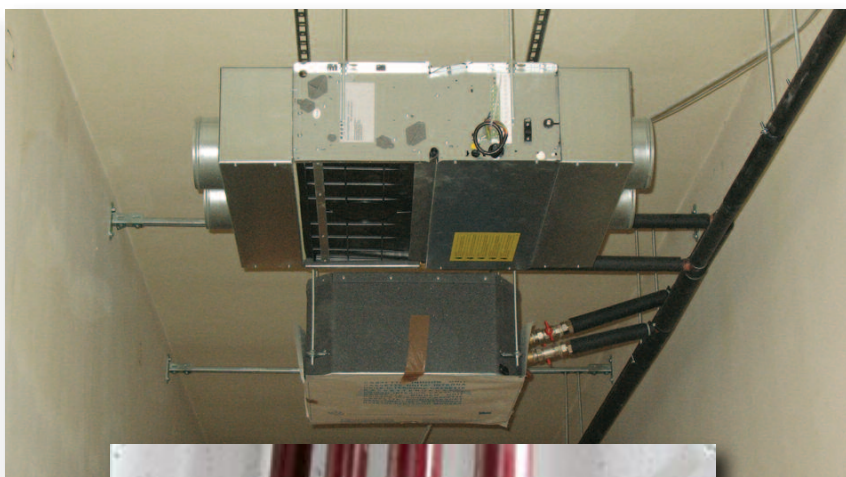

Fissaggi 01



CorRail



CorRail fixing rails and components

- F 2 Galvanised fixing rail
- F 3 CorRail Galvanised cantilever arm
- F 4 Square cantilever arm with rail prop obtained from fixing rail
- F 5 CorRail rail prop
- F 6 CorRail angle bracket
- F 7 CorRail longitudinal wall plate for fixing rails including slide nuts
- F 8 Tilttable longitudinal wall plate including slide nuts
- F 8 Wall plate for CH-32x20 fixing rail
- F 9 CorRail Slide nut
- F 10 Rhomboidal nut
- F 10 Double threaded plate
- F 11 Square slide nut
- F 11 Galvanised C washer
- F 12 CorRail Slide nut with threaded pin
- F 13 Hammer head screw
- F 14 Ball swivel hangers with height adjuster
- F 15 Pressure fixing element
- F 16 90° and 45° angle brackets
- F 17 Angle brackets
- F 18 CorRail® X and T connection including pre-assembled slide nuts
- F 19 CorRail Connection for fixing rails including pre-assembled slide nuts
- F 19 CorRail Height adjuster
- F 20 CorRail Pre-assembled cross rail connector
- F 21 Beam clamps for rails width 30 mm
- F 22 End cap for CorRail fixing rails
- F 22 EPDM sheath for fixing rails sound proofing and threaded rods

Technical data

Fixing rail section properties table

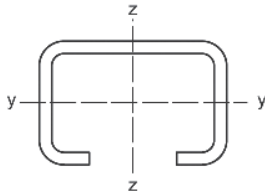

Type	Weight	Moment of inertia cm ⁴		Resistent moment cm ³	
	(kg / m)	I _y	I _z	W _y	W _z
CH0	0,57	0,28	0,91	0,30	0,67
CH1	0,87	0,28	1,47	0,35	0,98
CH15	0,86	0,49	1,66	0,49	1,10
CH	1,30	0,76	2,70	0,70	1,68
CH2	1,34	1,71	2,65	1,08	1,76
CH30	1,74	4,57	3,79	2,03	2,53

The stainless steel fixing rail values are higher than those reported above.

See the payloads table.

Type of drilling for the fastening of fixing rails to walls. The distance between the end of the fixing rail and the first hole is always the same.

CH0 (27 x 18 mm)

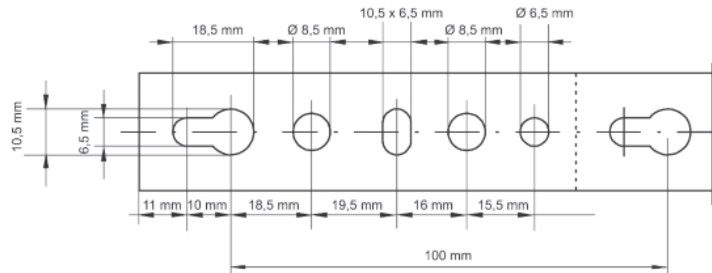

**CH1 (30 x 15 mm)
CH2 (30 x 30 mm)**

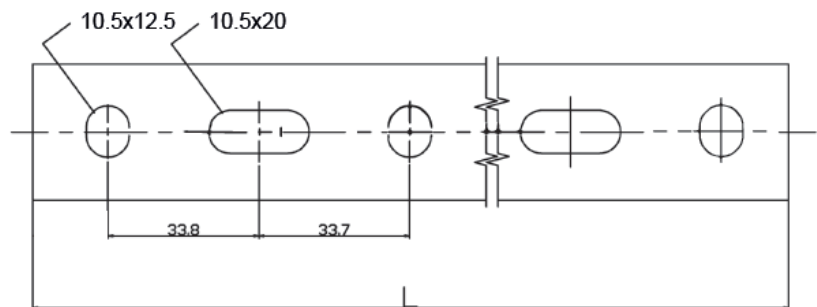
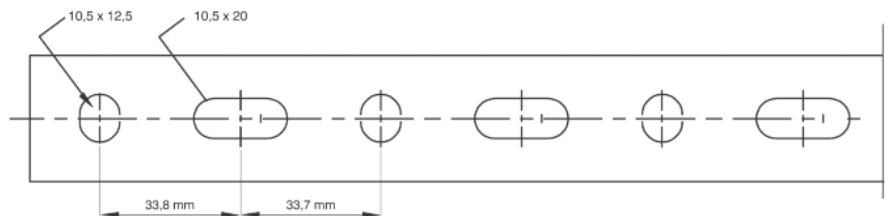

CH15 (30 x 20 mm)

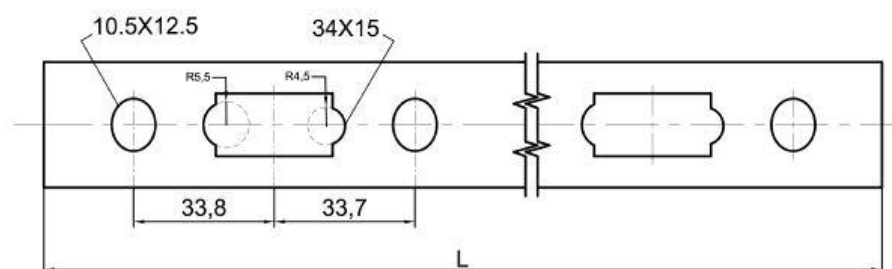

Art. 812 Galvanised fixing rail

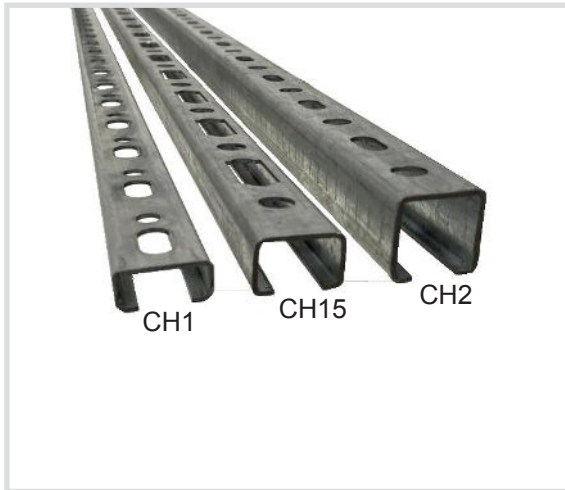

Technical specifications and advantages

- C Fixing rails
- The distance between the end of the fixing rail and the first hole is always the same
- Graduated scale centred on one side
- Made with pre-galvanised S235JR steel
- The special holes made for the CH15 and CH30 fixing rails allow fixing from both sides
- Plasticisation load 240 N/mm²



Code	Type	L [m]	Measurements (B x H) [mm]	s [mm]	S [mm]
812001	CH0	2	27 x 18	1,2	15
812002	CH1	2	30 x 15	2,0	15
812003	CH15	2	30 x 20	1,8	15
812004	CH	2	32 X 20	2,5	15
812005	CH2	2	30 x 30	2,0	15
812007	CH30	2	30 x 45	2,0	15

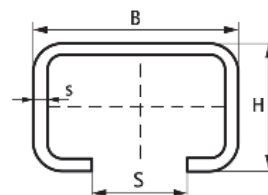

Art. 820 CorRail Galvanised cantilever arm



Technical specifications

- Made of S235JR steel
- Galvanised
- CO₂ welding
- Slots in the base at 90° for error-proof installation
- Graduated centimetre scale on one side
- If made with CH15 or CH30 fixing rail, fixing from both sides is possible

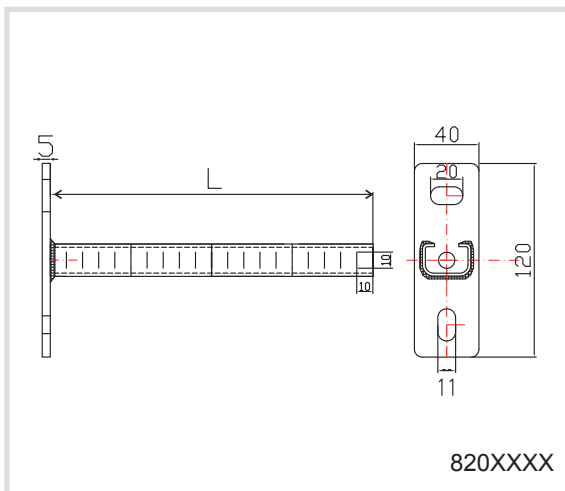

Code	L [mm]	Type Fixing rail	From [mm]
8200015	150	CH0	27 x 18
8200020	200	CH0	27 x 18
8201520	200	CH15	30 x 20
8200230	300	CH2	30 x 30
8200240	400	CH2	30 x 30
8200250	500	CH2	30 x 30



For further information on the maximum permitted loads, please refer to the load tables.

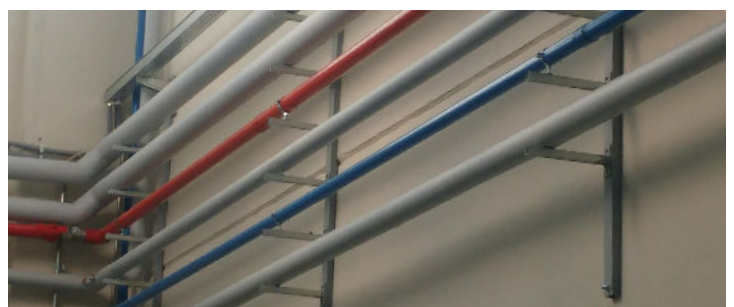

Art. 824 Square cantilever arm with rail prop obtained from fixing rail



Technical specifications and advantages

- Made with galvanised S235JR steel
- CO₂ welding
- Fixing rails used:
vertical and diagonal side: CH15 (30x20x1.8)
horizontal side: CH2 (30x30x2.0)
- With special holes for top-bottom assembly

Code	Measurements L [mm]	H [mm]	B x D [mm]	Thickness [mm]
824370	370	300	200 x 250	1,8
824545	545	380	290 x 380	2,0

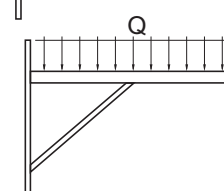
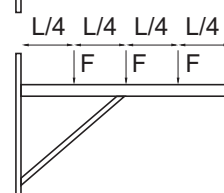
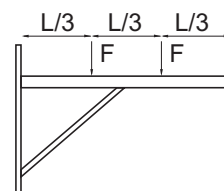
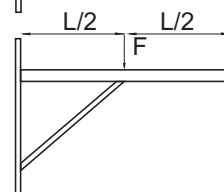
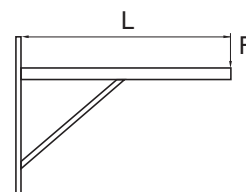
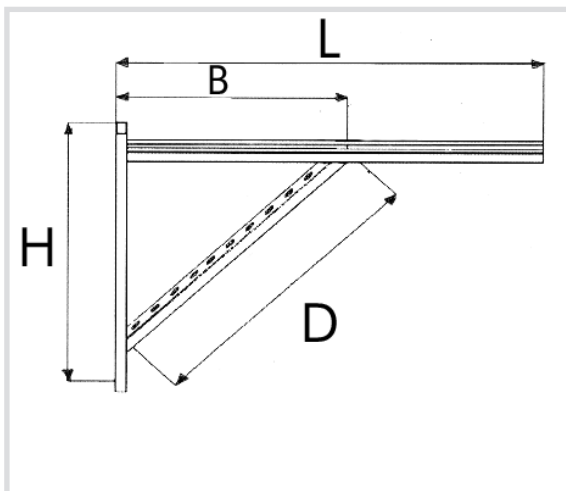

Maximum Payload [N]	
824370	824545

1.050	620
-------	-----

4.000	4.200
-------	-------

2.060	1.460
-------	-------

1.950	1.180
-------	-------

2.020	1.860
-------	-------

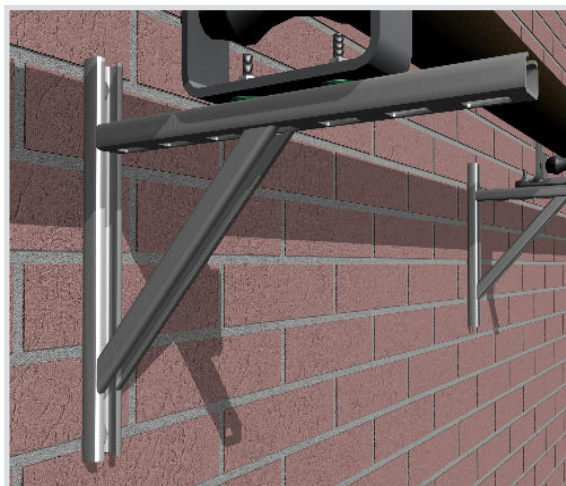

Art. 8994 CorRail rail prop



Technical specifications and advantages

- Made of galvanised steel
- CO₂ welding
- To increase the load with fixing above, below or on the side of the cantilever arm

Code	For fixing rails	H [mm]
899435	CorRail	350

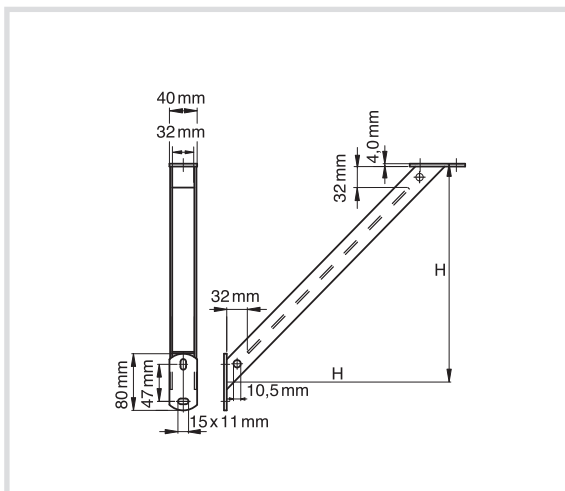

For the cantilever arm support of the 38x40 fixing rail, see the STRUT fixing rails category

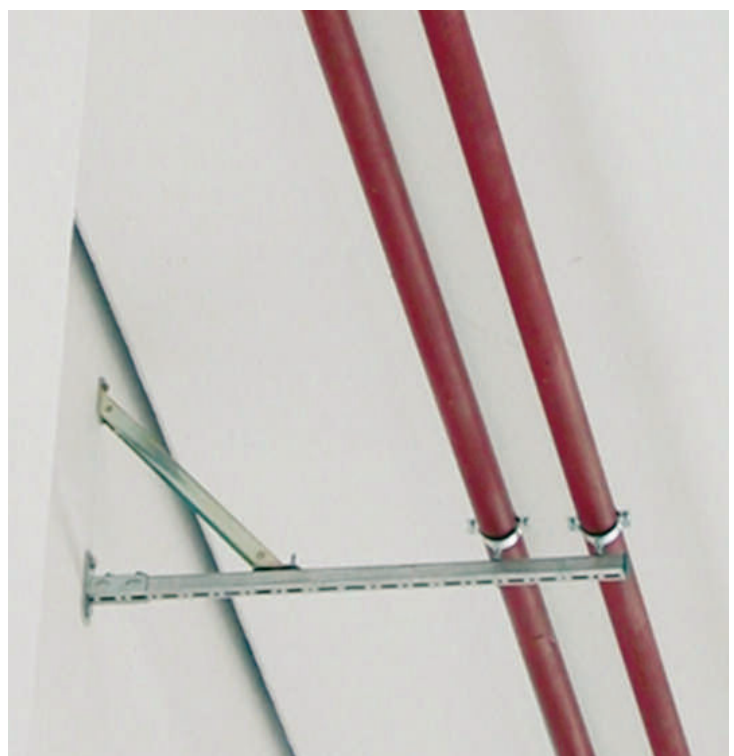
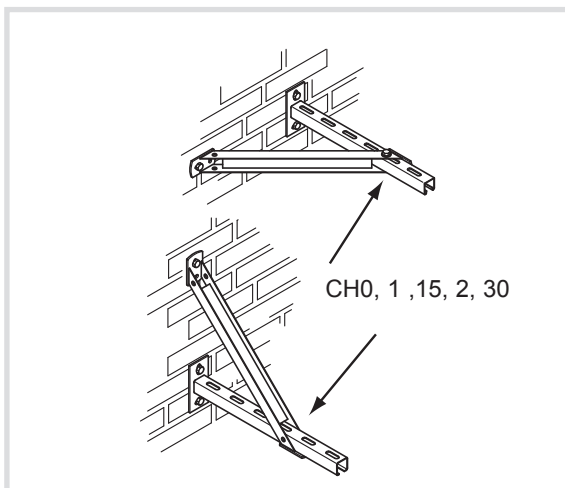

Art. 8993 CorRail angle bracket



Technical specifications and advantages

- Made of S235JR steel
- Galvanised
- Can also be used as a cantilever arm

Code	For fixing rails	Dimensions [mm]
899320	CorRail	200x200

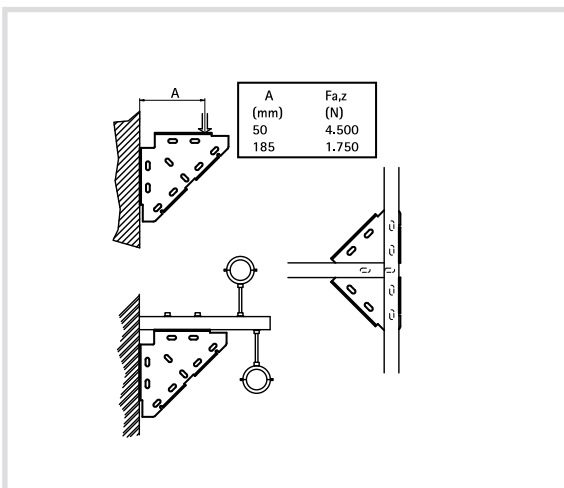
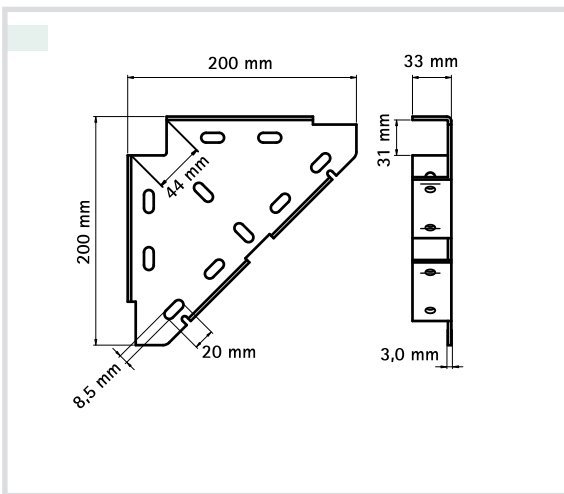

Art. 82020 CorRail longitudinal wall plate for fixing rails including slide nuts



Technical specifications and advantages

- Made of S235JR galvanised
- CO₂ welding
- Slots in the base at 90° for error-proof installation
- M8 x 16 bolts, DIN-EN 24017 (DIN 933)
- To create cantilever arms or support feet

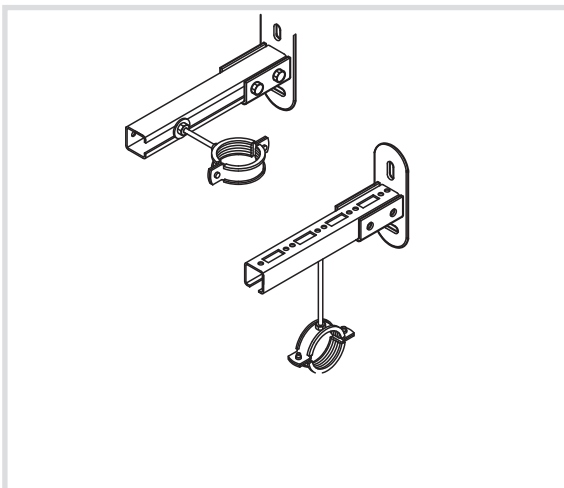
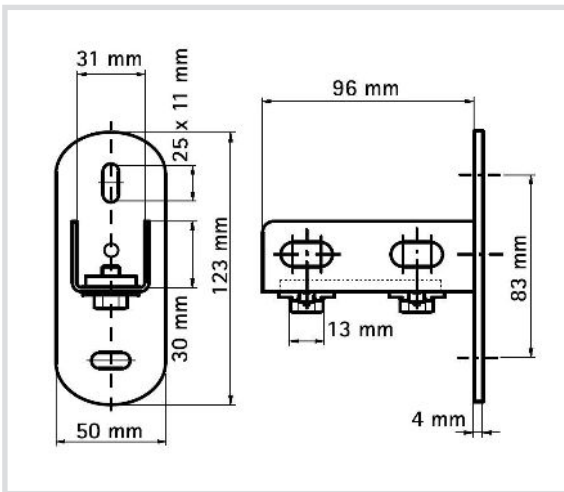

Code	Application
	Fixing rails
8202000	CH0, 1, 15, 2, 30



Art. 82022 Tiltable longitudinal wall plate including slide nuts

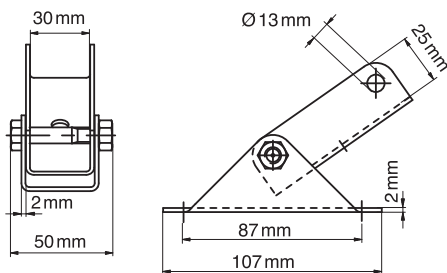

Technical specifications and advantages

- Tiltable wall support
- Also used to reinforce a construction made with CorRail
- Material: galvanised steel
- POM (polyoxymethylene) plastic springs, green
- To create cantilever arms or support feet

Code	Application Fixing rails
8202200	CH0, 1, 15, 2, 30

Art. 822003 Wall plate for CH-32x20 fixing rail



Caratteristiche tecniche

- To create cantilever arms or support feet
- Material: galvanised steel

Code	Fixing rail
822003	CH 32x20

Art. 8203 CorRail Slide nut



Technical specifications and advantages

- With pre-assembled plastic spring for easy assembly
- Suitable for all CorRail fixing rails
- Materials: metal parts in 1.0332 steel, spring in polyoxymethylene (POM), green
- Galvanised

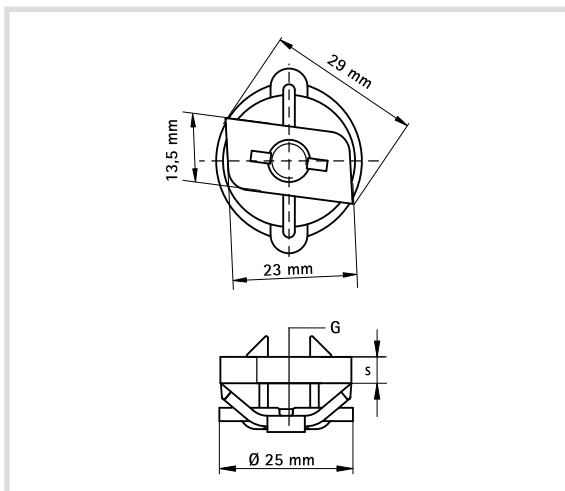

Code	G	s [mm]	T [Nm]	Payload [N]
8203006	M6	4	7,5	2000
8203008	M8	5	15	2700
8203010	M10	5	15	2900



Art. 960/6519 Rhomboidal nut



Technical specifications and advantages

- For the attachment of bolts and threaded parts to fixing rails
- Made of galvanised steel
- For the CH0, 1, 15, 2, 30 and CH fixing rails
- Material: galvanised steel

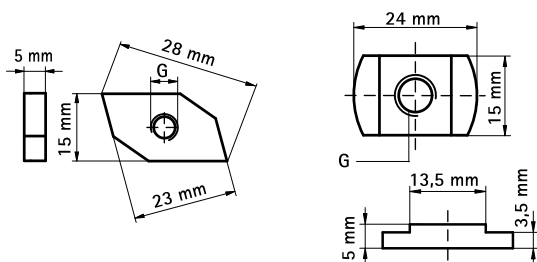

Code	G [mm]	For fixing rails	Payload [N]
960006	M6	CH1, CH15, CH, CH2, CH30	
960008	M8	CH1, CH15, CH, CH2, CH30	
960010	M10	CH1, CH15, CH, CH2, CH30	
6519006	M6	CH0	3100
6519008	M8	CH0	3100
6519010	M10	CH0	3100

Art. 8992 Double threaded plate



Technical specifications and advantages

- Made of steel
- Suitable for all CorRail fixing rails

Code	G	L [mm]	For fixing rails
899274	M8	74	CorRail

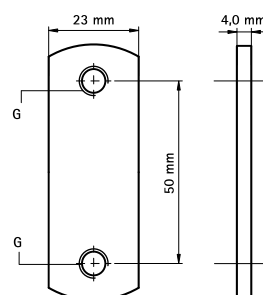

Art. 9012 Square slide nut

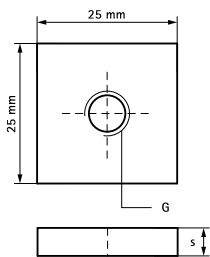

Technical specifications and advantages

- To attach any threaded component to the CorRail
- Made with galvanised steel
- Material: galvanised steel 1.0332

Code	G	Fixing rails	s
901206	M6	CH1, 15, 2, 30 e CH	4,0
901208	M8	CH1, 15, 2, 30 e CH	4,0
901210	M10	CH1, 15, 2, 30 e CH	5,0
901212	M12	CH1, 15, 2, 30 e CH	5,0

Art. 9011 Galvanised C washer

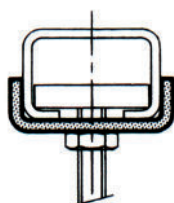

Technical specifications and advantages

- Made of galvanised steel
- Packs of 25 pieces

Code	Hole/Screw Ø [mm]	B [mm]	H [mm]
901110	10,5	30,5	11,0
901112	12,5	30,5	11,0

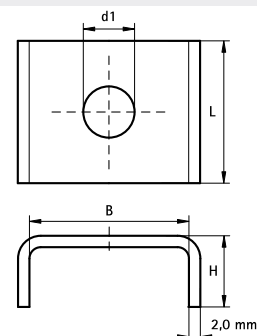

Art. 821 CorRail Slide nut with threaded pin



Technical specifications and advantages

- Made with 1.0332 galvanised steel
- With a plastic spring that keeps the piece assembled in the desired position until tightening
- Spring material: POM (polyoxymethylene), green
- Pin height adjustment
- Suitable for all CorRail fixing rails

Code	G	L [mm]	SW1 [mm]	LU [mm]	s [mm]	Payload [N]
8210830	M8	30	13	12	5	2700
8210840	M8	40	13	22	5	2700
8210860	M8	60	13	42	5	2700
8210880	M8	80	13	62	5	2700
8210810	M8	100	13	82	5	2700
8211030	M10	30	17	12	5	2900
8211040	M10	40	17	22	5	2900
8211060	M10	60	17	42	5	2900
8211080	M10	80	17	62	5	2900
8211100	M10	100	17	82	5	2900

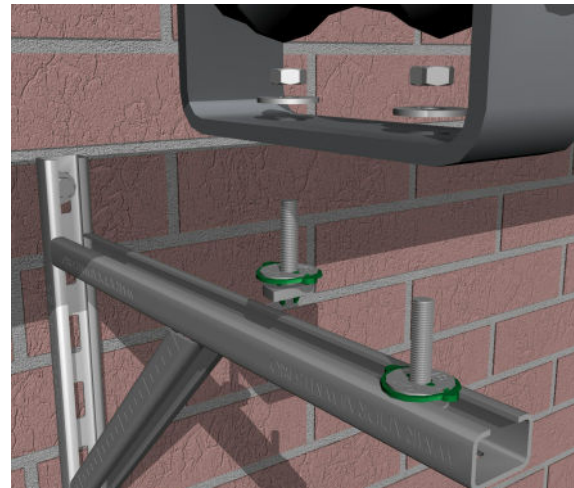
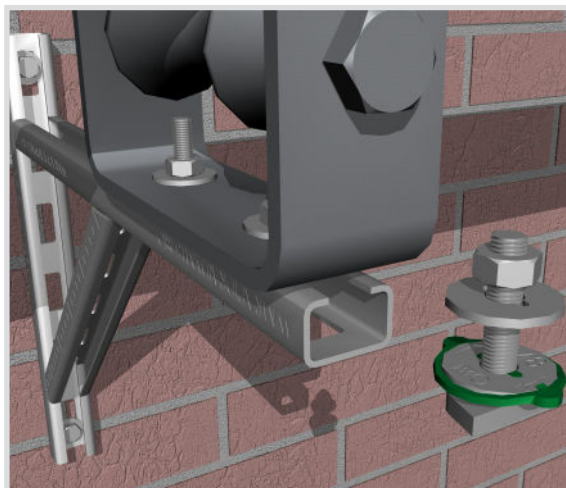
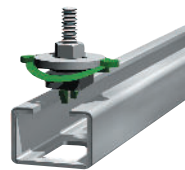
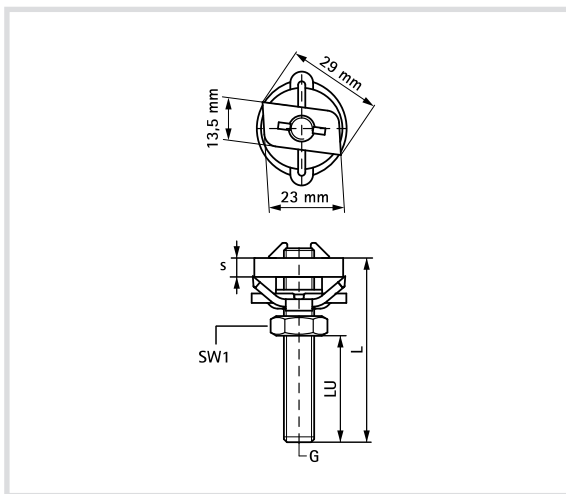

Art. 6590 Hammer head screw



Technical specifications and advantages

- Material: S235JR steel
- Galvanised
- For any type of threaded fixing on the fixing rails
- For all types of CorRail

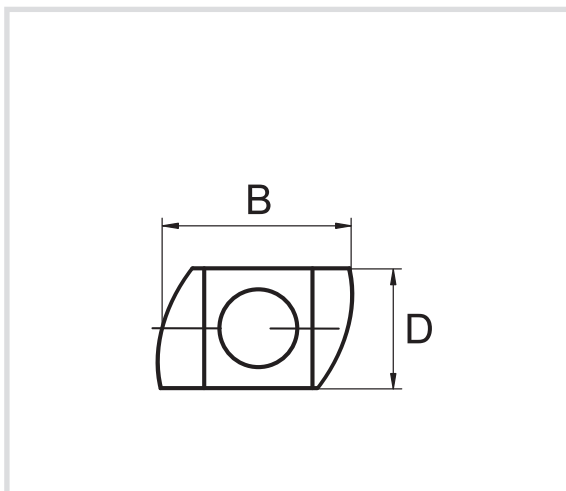

Code	L	G	H [mm]	B [mm]	D [mm]
659001	30	M8	6	25	12
659003	30	M10	6	25	12

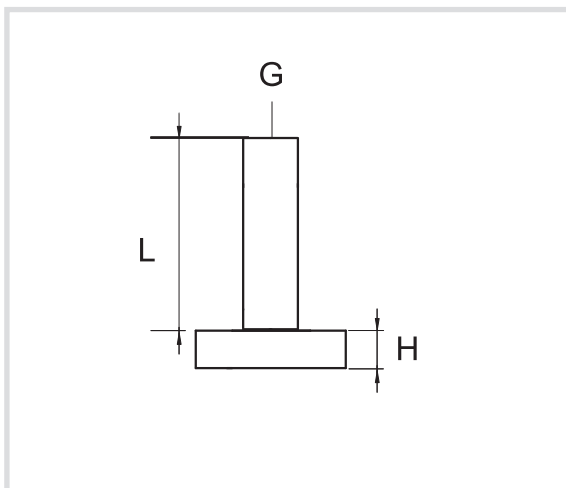

Art. 6520 Ball swivel hangers with height adjuster



Technical specifications

- Made with 1.0332 steel
- With inspection hole to check the adjustment
- Guaranteed adjustment
- The height of the collar can also be changed after assembly
- Material: galvanised steel
- Spring: POM (polyoxymethylene), green
- For all CorRail fixing rails

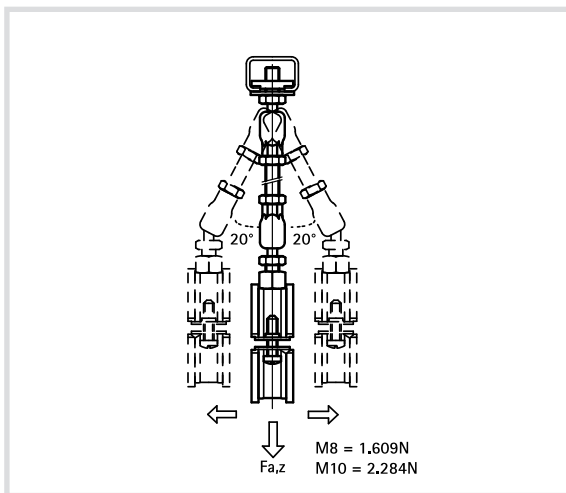

Code	G	L [mm]	Lm1 [mm]	SW1 [mm]	LU [mm]
6520200	M8	70	50	10	43
6520210	M10	70	50	12	43

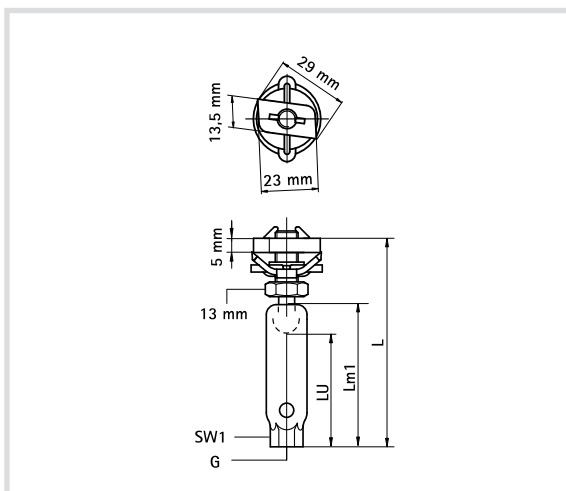

Art. 89910 Pressure fixing element



Technical specifications and advantages

- Made of 1.0332 galvanised steel
- CO₂ welding
- To connect to a steel support without welding or drilling
- For all the CorRaili fixing rails

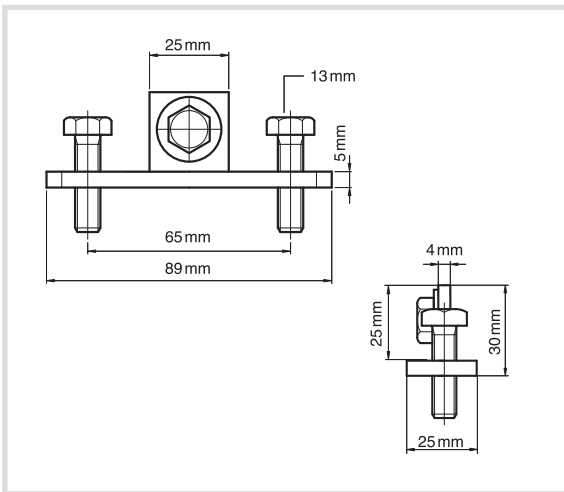

Code	For fixing rails
899100	CorRail

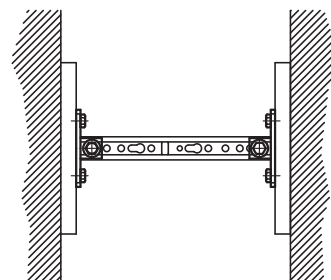
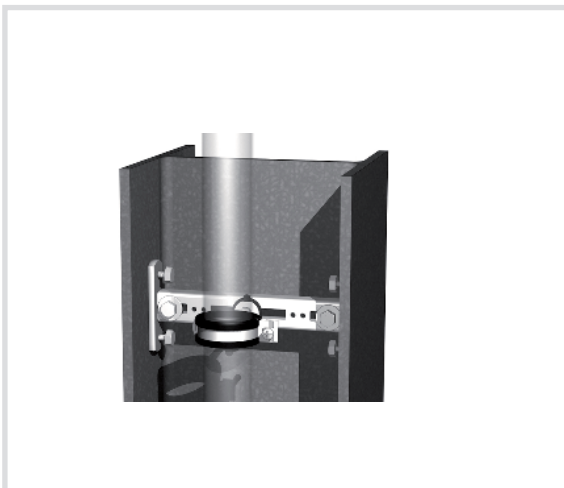

Art. 658 90° and 45° angle brackets



Technical specifications and advantages

- Made with 1.0332 galvanised steel
- To build supports or suspension elements
- Including pre-assembled slide nut to hold the piece in place before tightening
- Guaranteed adjustment
- POM spring (polyoximethylene), green
- For all CorRail fixing rails



Code	Model	Angles	Payload [N]
658301	long / long	90°	1562
658302	short / short	90°	1336
658303	long / long	135°	1562

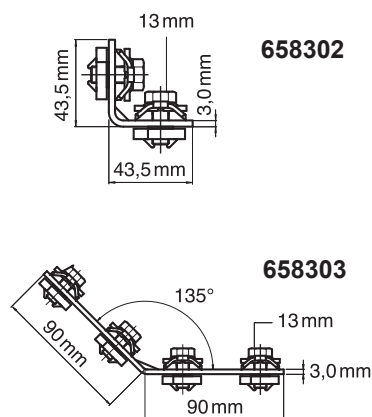
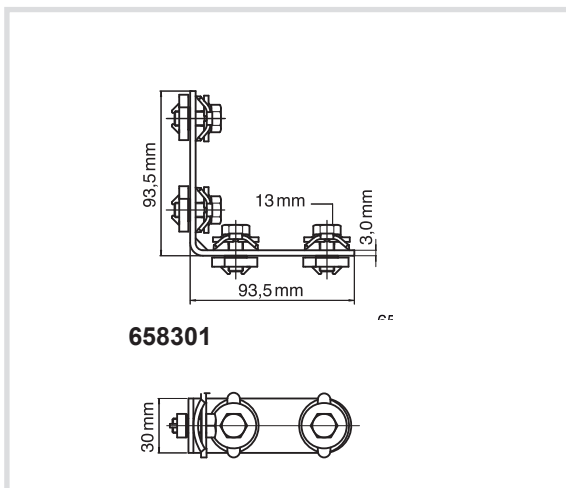

Art. 658 Angle brackets



658001

Technical specifications and advantages

- Made with galvanised steel
- To build structures with fixing rails
- Suitable for all CorRail fixing rails



658003

Code	Type
658001	90° angle bracket
658003	45° angle bracket

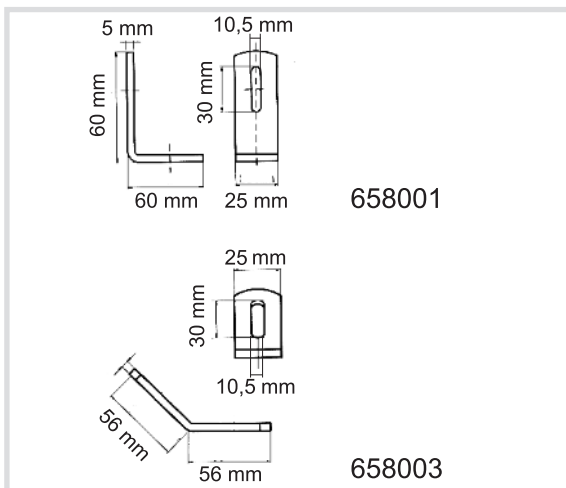

658001

658003

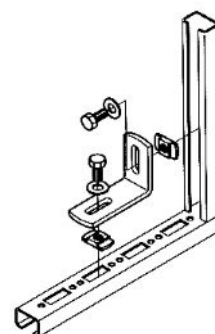

Art. 65810 CorRail® X and T connection including pre-assembled slide nuts

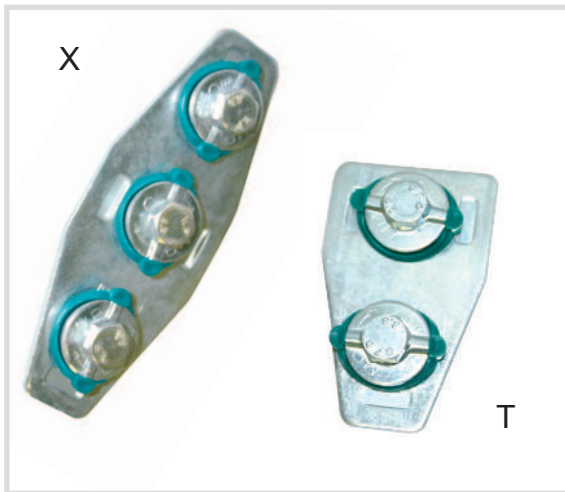

Technical specifications and advantages

- Made with 1.0332 steel
- Galvanised
- Plastic spring in POM (Polyoxymethylene), green
- To build structures
- Includes pre-assembled slide nuts to hold the piece in place before tightening
- For all CorRail fixing rails

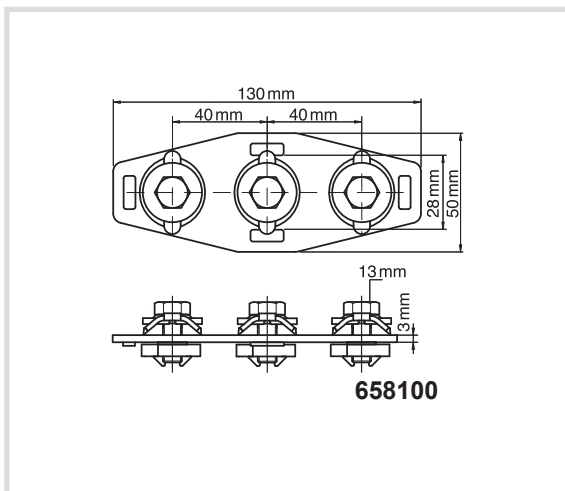

Code	Type	For fixing rails	Fa,x RAL [N]
658100	X	CorRail	345
658101	T	CorRail	345

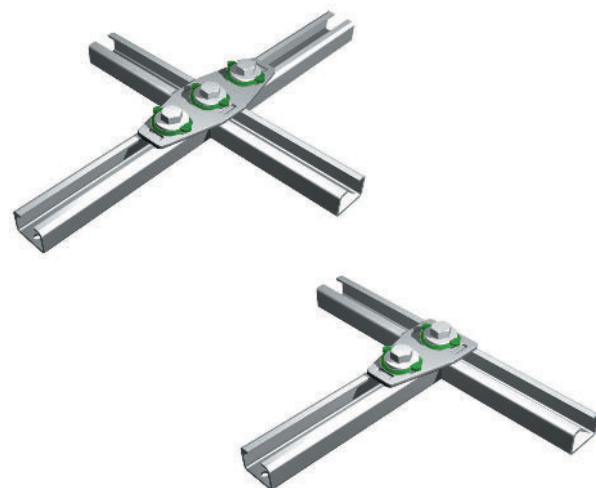
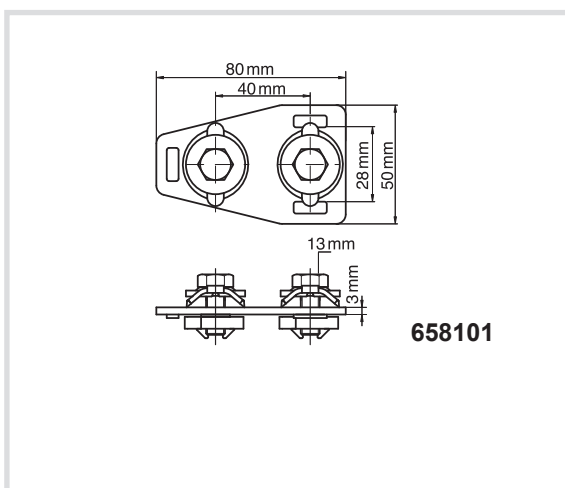

Art. 6582 CorRail Connection for fixing rails including pre-assembled slide nuts



Technical specifications and advantages

- Made of 1.0332 steel
- Galvanised
- Plastic spring in POM (Polyoxymethylene), green

Code	For fixing rails	Payload [N]
658200	CH0, 1, 15, 2, 30, 35	1550

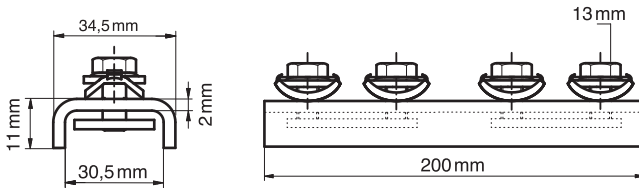

Art. 679 CorRail Height adjuster



Technical specifications and advantages

- Made with 1.0332 Galvanised steel
- Suitable for CorRail fixing rails
- With DIN-EN 24017 hexagonal head screw and Ø25 mm washer
- Plastic spring in POM oil-oxymethylene), green

Code	G Ø [mm]	T [Nm]	Fa,z [N]	Fa,x [N]
6793008	M8	15	1600	79

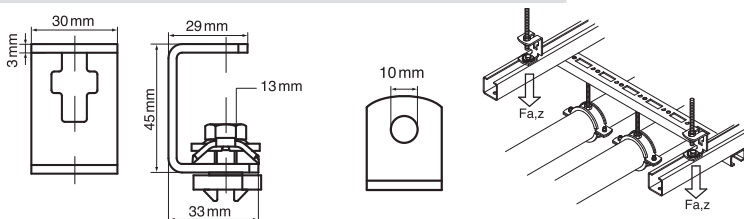

Art. 8994 CorRail Pre-assembled cross rail connector



Technical specifications and advantages

- Made with 1.0332 steel
- Galvanised
- Plastic spring in POM (polyoxymethylene), green

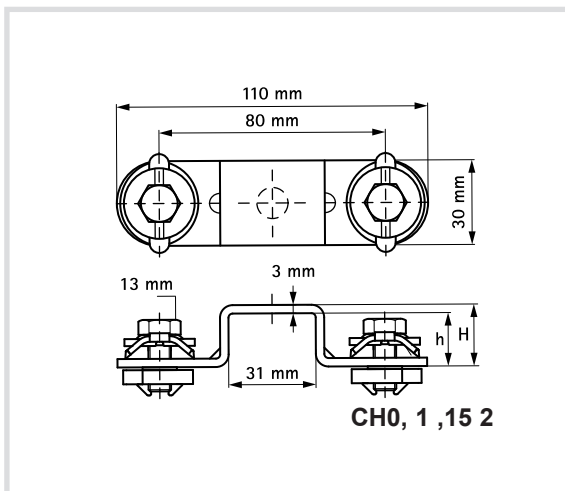

Code	Suitable Fixing rails	H [mm]	h [mm]	Fa,z [N]	Fa,x [N]
899401	CH0	20	17	1226	689
899402	CH1	17	14	1226	689
899403	CH15	22	19	1226	689
899405	CH2	32	29	1226	689



Art. 8995 Beam clamps for rails width 30 mm



Technical specifications and advantages

- Made of galvanised steel
- To connect to a steel support without welding or drilling
- Always use 2 plates to attach to a beam

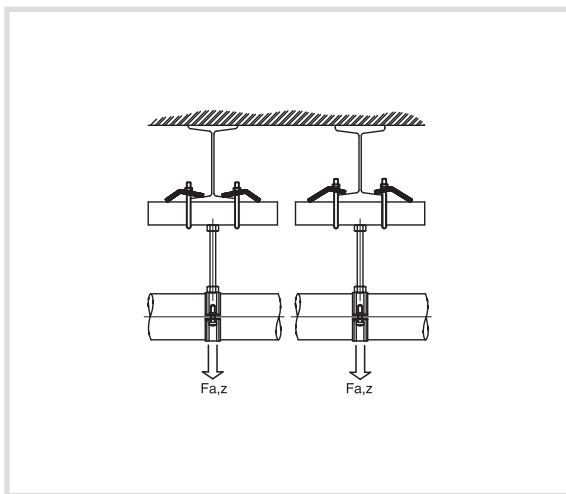

Code	A [mm]	For fixing rails	Payload [N]
899505	< 16	CH0, 1, 15, 2, 30	4500

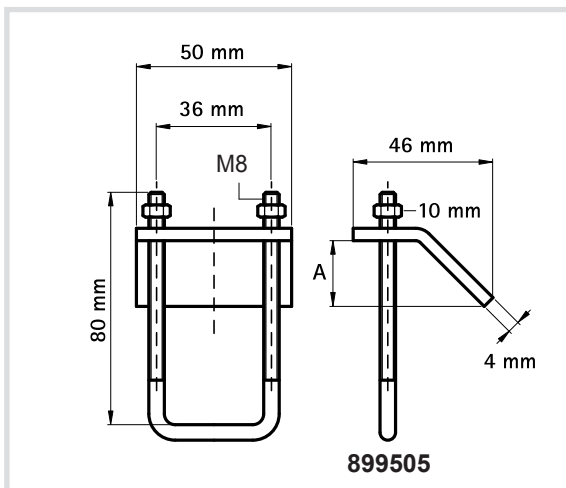

Art. 8100 End cap for CorRail fixing rails

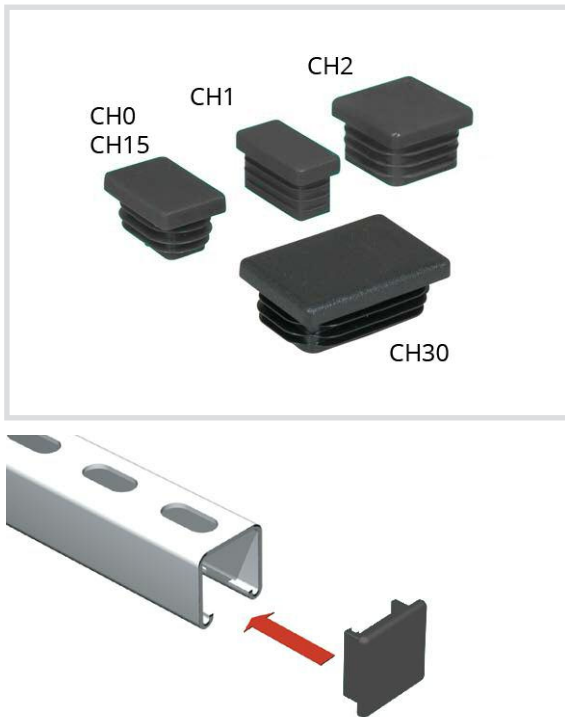

Technical specifications

- Made with PE (polyethylene)
Colour: Black
- The function of the cap is decorative and protective: the sharp edges generated by the fixing rail cut are completely covered

Code	Measurements [mm]	For fixing rail
810001	30 x 15 CH1	CH1
810015	27 x 18 CH0	CH0, 15
810002	30 x 30 CH2	CH2
810030	30 x 45 CH30	CH30

Art. 89900 EPDM sheath for fixing rails sound proofing and threaded rods



Technical specifications

- Made of EPDM rubber, black
- Also suitable for M6, M8, M10 threaded rods
- Noise insulation according to DIN 4109
- Resistant to ageing

Code	R	Length [metres]	Fixing rails
899000	M6 - M10	30	CorRail

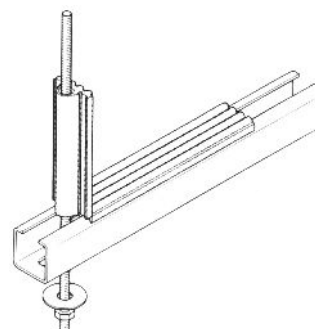
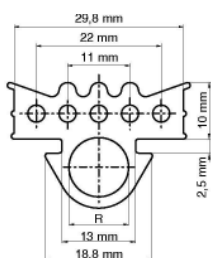

Calculation method

The published payloads are based on tests with perforated fixing rails. For non-perforated fixing rails, 20% higher payload than the one reported.

The loads are calculated considering a maximum deflection (f) of a value equal to $1/200 \times L$ and a maximum bending load of 160 N/mm^2 .

Example: for a length of 500 mm the maximum payload is 1400 N; the maximum deflection will be $(1/200 \times 500 \text{ mm}) = 2.5 \text{ mm}$
 $1 \text{ N (Newton)} = 0.102 \text{ kg}$ $1 \text{ kg} = 9.8 \text{ N (Newton)}$

Attaching of the fixing rail to walls or partitions

The anchoring force of the fixing rail has not been taken into consideration.

The installer must check that the screws and anchors used to attach the fixing rail to the wall or ceiling are suitable for the maximum load permitted by the fixing rail.

Loading methods

Where loads are suspended on the fixing rails, the load must not exceed the safe payload of the attachment to the fixing rail. To increase the rigidity of the installation we recommend the use of U washers.

When loading is from above the fixing rail, the possible load is greater than that shown in the tables.

How to read load tables

Where the box is empty, it is not possible to use the fixing rail selected for that application and it will be necessary to use one with a higher range.

Special conditions

In case of uncertainty or special conditions not shown in the load tables, do not hesitate to contact our technical department for suggestions and advice.

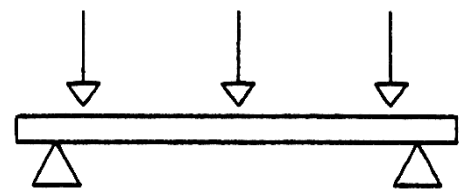
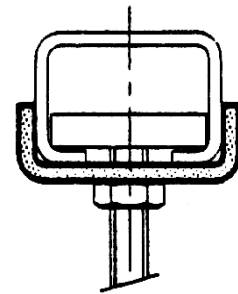
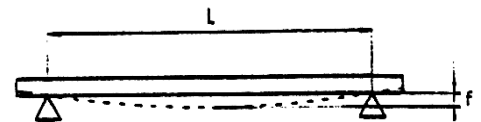

Load from above

C fixing rail

1 point suspension

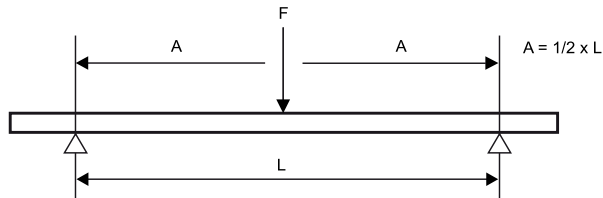

L (mm)	CH0 (27 x 18)	CH1 (30 x 15)	CH15 (30 x 20)	CH (32 x 20)	CH2 (30 x 30)	CH30 (30 x 45)
250	758	899	1.249	1.951	3.238	5.199
300	631	749	1.041	1.626	2.698	4.333
350	541	642	892	1.393	2.313	3.714
400	474	562	781	1.219	2.023	3.250
450	421	499	694	1.084	1.799	2.889
500	379	449	625	975	1.619	2.600
600	316	358	521	813	1.349	2.166
700	266	263	446	697	1.156	1.857
800	204	202	348	571	1.012	1.625
900	161	159	275	451	899	1.444
1.000	130	129	223	366	780	1.300
1.200	91	90	155	254	542	1.083
1.400	67	66	114	187	398	928
1.600	51	50	87	143	305	812
1.800	40	40	69	113	241	643
2.000	33	32	56	91	195	521
2.250	26	25	44	72	154	412
2.500	21	21	36	58	125	333
2.750	17	17	29	48	103	275
3.000	14	14	25	41	87	231
3.250	12	12	21	35	74	197
3.500	11	11	18	30	64	170
3.750	-	-	16	26	55	148
4.000	-	-	14	23	49	130
4.250	-	-	12	20	43	115
4.500	-	-	11	18	39	103
4.750	-	-	-	16	35	92
5.000	-	-	-	15	31	83
5.250	-	-	-	13	28	76
5.500	-	-	-	12	26	69
5.750	-	-	-	11	24	63
6.000	-	-	-	10	22	58

Maximum payload in N.

The values reported are only valid for the fixing rail.
The maximum payload of all the other construction parts must be verified.

C fixing rail

2 equal loads

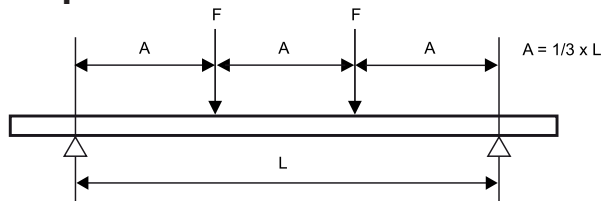

L (mm)	CH0 27 x 18	CH1 30 x 15	CH15 30 x 20	CH 32 x 20	CH2 30 x 30	CH30 30 x 45
250	568	674	937	1.463	2.428	3.900
300	474	562	781	1.219	2.023	3.250
350	406	481	669	1.045	1.734	2.785
400	355	421	586	914	1.518	2.437
450	316	374	521	813	1.349	2.166
500	284	303	468	732	1.214	1.950
600	213	210	363	596	1.012	1.625
700	156	155	267	438	867	1.393
800	120	118	204	335	715	1.219
900	95	94	161	265	565	1.083
1.000	77	76	131	215	458	975
1.200	53	53	91	149	318	812
1.400	39	39	67	109	234	624
1.600	30	30	51	84	179	478
1.800	24	23	40	66	141	377
2.000	19	19	33	54	114	306
2.250	15	15	26	42	90	242
2.500	12	12	21	34	73	196
2.750	10	10	17	28	61	162
3.000	-	-	15	24	51	136
3.250	-	-	12	20	43	116
3.500	-	-	11	18	37	100
3.750	-	-	-	15	33	87
4.000	-	-	-	13	29	76
4.250	-	-	-	12	25	68
4.500	-	-	-	11	23	60
4.750	-	-	-	-	20	54
5.000	-	-	-	-	18	49
5.250	-	-	-	-	17	44
5.500	-	-	-	-	15	40
5.750	-	-	-	-	14	37
6.000	-	-	-	-	13	34

Max payload in N. Suspension for point (F)

The values reported are only valid for the fixing rail.
The maximum payload of all the other construction parts must be verified.

C fixing rail

3 equal loads

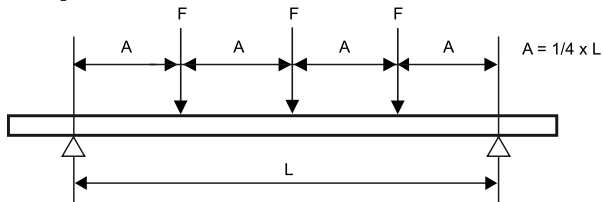

L (mm)	CH0 (27 x 18)	CH1 (30 x 15)	CH15 (30 x 20)	CH (32 x 20)	CH2 (30 x 30)	CH30 (30 x 45)
250	379	449	625	975	1.619	2.600
300	316	374	521	813	1.349	2.166
350	271	321	446	697	1.156	1.857
400	237	281	390	610	1.012	1.625
450	210	250	347	542	899	1.444
500	189	217	312	488	809	1.300
600	153	151	260	406	674	1.083
700	112	111	191	314	578	928
800	86	85	147	241	506	812
900	68	67	116	190	406	722
1.000	55	54	94	154	328	650
1.200	38	38	65	107	228	542
1.400	28	28	48	79	168	448
1.600	21	21	37	60	128	343
1.800	17	17	29	48	101	271
2.000	14	14	23	38	82	219
2.250	11	11	19	30	65	173
2.500	-	-	15	25	53	140
2.750	-	-	12	20	43	116
3.000	-	-	10	17	36	97
3.250	-	-	-	15	31	83
3.500	-	-	-	13	27	72
3.750	-	-	-	11	23	62
4.000	-	-	-	-	21	55
4.250	-	-	-	-	18	49
4.500	-	-	-	-	16	43
4.750	-	-	-	-	15	39
5.000	-	-	-	-	13	35
5.250	-	-	-	-	12	32
5.500	-	-	-	-	11	29
5.750	-	-	-	-	-	27
6.000	-	-	-	-	-	24

Max payload in N. Suspension for point (F)

The values reported are only valid for the fixing rail.
The maximum payload of all the other construction parts must be verified.

C fixing rail

Load distributed uniformly

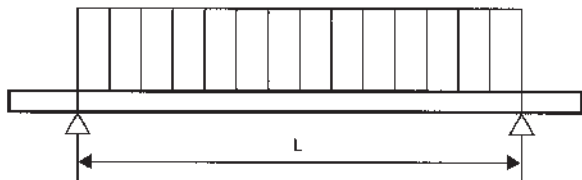

L (mm)	CH0 27 x 18	CH1 30 x 15	CH15 30 x 20	CH 32 x 20	CH2 30 x 30	CH30 30 x 45
250	1.516	1.797	2.499	3.901	6.475	10.399
300	1.263	1.498	2.082	3.251	5.396	8.666
350	1.083	1.284	1.785	2.787	4.625	7.428
400	947	1.123	1.562	2.438	4.047	6.499
450	842	998	1.388	2.167	3.597	5.777
500	758	826	1.249	1.951	3.238	5.199
600	580	574	990	1.625	2.698	4.333
700	426	421	727	1.194	2.313	3.714
800	326	323	557	914	1.950	3.250
900	258	255	440	722	1.541	2.889
1.000	209	206	356	585	1.248	2.600
1.200	145	143	248	406	867	2.166
1.400	106	105	182	298	637	1.701
1.600	82	81	139	228	488	1.302
1.800	64	64	110	181	385	1.029
2.000	52	52	89	146	312	833
2.250	41	41	70	116	247	658
2.500	33	33	57	94	200	533
2.750	28	27	47	77	165	441
3.000	23	23	40	65	139	370
3.250	20	20	34	55	118	316
3.500	17	17	29	48	102	272
3.750	15	15	25	42	89	237
4.000	13	13	22	37	78	208
4.250	12	11	20	32	69	185
4.500	10	10	18	29	62	165
4.750	-	-	16	26	55	148
5.000	-	-	14	23	50	133
5.250	-	-	13	21	45	121
5.500	-	-	12	19	41	110
5.750	-	-	11	18	38	101
6.000	-	-	-	16	35	93





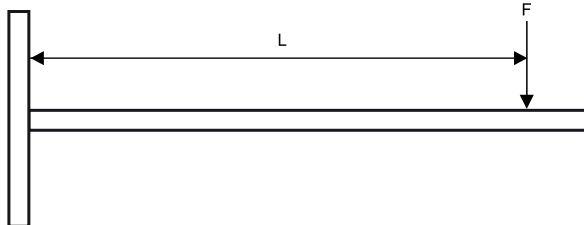

Max payload in N. Suspension for point (F)

The values reported are only valid for the fixing rail.
The maximum payload of all the other construction parts must be verified.

Rail cantilever arm

1 point suspension



L (mm)						
	CH0 27 x 18	CH1 30 x 15	CH15 30 x 20	CH 32 x 20	CH2 30 x 30	CH30 30 x 45
100	474	562	781	1.219	2.023	3.250
150	316	358	521	813	1.349	2.166
200	204	202	348	571	1.012	1.625
250	130	129	223	366	780	1.300
300	91	90	155	254	542	1.083
350	67	66	114	187	398	928
400	51	50	87	143	305	812
450	40	40	69	113	241	643
500	33	32	56	91	195	521
550	27	27	46	76	161	430
600	23	22	39	63	135	362
700	17	16	28	47	100	266
800	13	13	22	36	76	203
900	10	-	17	28	60	161
1.000	-	-	14	23	49	130
1.100	-	-	12	19	40	108
1.200	-	-	-	16	34	90
1.300	-	-	-	14	29	77
1.400	-	-	-	12	25	66
1.500	-	-	-	10	22	58

Max payload in N.

The values reported are only valid for the fixing rail.
The maximum payload of all the other construction parts must be verified.

Rail cantilever arm

Load distributed uniformly

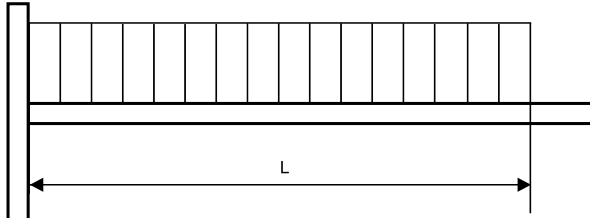

L (mm)						
	CH0 27 x 18	CH1 30 x 15	CH15 30 x 20	CH 32 x 20	CH2 30 x 30	CH30 30 x 45
100	947	1.123	1.562	2.438	4.047	6.499
150	631	749	1.041	1.626	2.698	4.333
200	474	538	781	1.219	2.023	3.250
250	348	344	594	975	1.619	2.600
300	242	239	413	677	1.349	2.166
350	177	176	303	497	1.061	1.857
400	136	134	232	381	813	1.625
450	107	106	183	301	642	1.444
500	87	86	149	244	520	1.300
550	72	71	123	201	430	1.148
600	60	60	103	169	361	965
700	44	44	76	124	265	709
800	34	34	58	95	203	543
900	27	27	46	75	161	429
1.000	22	22	37	61	130	347
1.100	18	18	31	50	107	287
1.200	15	15	26	42	90	241
1.300	13	13	22	36	77	205
1.400	11	11	19	31	66	177
1.500	-	-	17	27	58	154

Max payload in N.

The values reported are only valid for the fixing rail.
The maximum payload of all the other construction parts must be verified.