

Art. 812520 Slotted CorSTRUT fixing rail

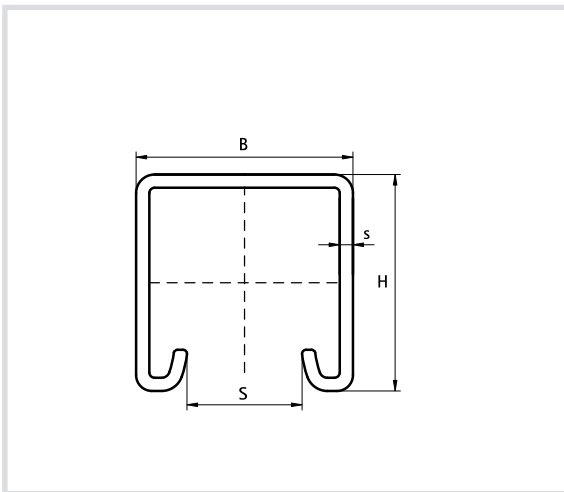

*Technical specifications and advantages*

- Made of pre-galvanised S235JR steel
- The distance between the end of the fixing rail and the first hole is always the same
- Available with hot-dip galvanisation (upon request)
- Tested for safety against fire
- With notches on the inside for greater adhesion of the components
- Slotted on all sides of the fixing rail



Code	Measurements B x H [mm]	Thickness (s) [mm]	Length [mm]	S [mm]
<b>812520</b>	41 x 41	2,5	3000	22

